























Index

Introduction		
Direct Acting		“XM” Series
		15mm Solenoid Valve
Stacking		Moduflex Series
		“PVL” Series
Inline		“EZ” Series
		“B” Series
		Viking Xtreme
		“ADEX” Series
		“N” Series
Subbase & Manifold		Isys Micro Series
		Isys ISO Series
		Isysnet
		“DX” ISOMAX Series
		Valvair II
Manual Mechanical		Directair 2 Series, Manual/Mechanical
		Directair 4 Series, Manual/Mechanical
		“42” Lever / Pedal Series
		“M0” Series
		“LV” / “EZ” Lockout Valves
		Brass Poppet / Sliding Seal / “PL” / “VL” / “HV”
Accessories		Control Panel Products
		Sensing
		Flow Controls & Accessories
Safety Guide, Offer of Sale		

Index

<ul style="list-style-type: none"> • Other Products • Valve Selector Chart (By Flow) • Fieldbus Solutions Guide • Fluid Power Graphic Symbols • Technical Information • 5-Year Warranty 		A
<ul style="list-style-type: none"> • Direct Acting Solenoid • 3-Way & 4-Way • Inline • IEM Bar Manifold • Subbase Valve Manifolds • .15 Cv 	www.parker.com/pneu/xm	B
<ul style="list-style-type: none"> • Compact & Simplified Design • Subbase or Manifold Option • 3-Way • NO & NC on Same Manifold • Wide Range of Voltage • .033 to .05 Cv 	www.parker.com/pneu/15mm	Direct Acting
<ul style="list-style-type: none"> • Stand Alone Valves • Valve Island • Collective Wiring or Fieldbus Configuration • 3-Way & 4-Way • Modular & Flexible Design • Multiple Pressure Option • Compact & Low Weight • .18 to .80 Cv 	www.parker.com/pneu/moduflex	C
<ul style="list-style-type: none"> • Compact Composite Design • Modular with a Wide Range of Voltages • 3-Way & 4-Way • Fieldbus Available • .6 to 1.2 Cv 	www.parker.com/pneu/pvl	Stacking
<ul style="list-style-type: none"> • Wear Compensating Dynamic Sealing System • Economical Solution • Optimized Design for Industrial Markets • Simplified Design • .8 to 2.4 Cv 	www.parker.com/pneu/EZInline	D
<ul style="list-style-type: none"> • Wide Range of Sizes & Flows • Multiple Options • IEM Bar Manifold • 3-Way & 4-Way • Wear Compensating Dynamic Sealing System • .75 to 7.0 Cv 	www.parker.com/pneu/b	Inline
<ul style="list-style-type: none"> • Extreme Temperature & Pressure Ranges • ATEX Options • 4-Way • Wide Range of Voltages for Mobile Industries • Unique Overmoulded Spool Technology • .7 to 2.7 Cv 	www.parker.com/pneu/vikingx	D
<ul style="list-style-type: none"> • 10mm 3-Way • 15mm & 20mm 4-Way • Low Power Consumption • Subbase & Inline Body • Individual & Collective Wiring Solutions • .01 to .47 Cv 	www.parker.com/pneu/adex	D
<ul style="list-style-type: none"> • Robust Poppet Design • Fast Response & High Flow • 2-Way & 3-Way • High Maximum Pressure Option • 3.6 to 29.9 Cv 	www.parker.com/pneu/n	D
<ul style="list-style-type: none"> • Compact Valves with High Flow • Innovative Back to Back Mounting Style with 4 Valves in a 42mm Width • Plug-in Design with Collective Wiring on Fieldbus or 25 Pin Cable • .35 Cv 	www.parker.com/pneu/isysmicro	E
<ul style="list-style-type: none"> • ISO Valve Platform, 18mm, 26mm, Size 1, Size 2, & Size 3 Plug-in • Collective Wiring on Fieldbus or 25-Pin or M23 Cable • Non Plug-in Valves with 3-Pin Din or Mini Connectors • .55 to 6.0 Cv 	www.parker.com/pneu/isys	Subbase & Manifold
<ul style="list-style-type: none"> • Fieldbus Interface for Isys Valves • Added Input & Output Functionality • Up to 256 Inputs & 256 Outputs • Digital or Analog 	www.parker.com/pneu/isysnet	E
<ul style="list-style-type: none"> • ISO Valve Platform, 18mm, 26mm, Size 1, Size 2, & Size 3 • Non Plug-in Valves with 3-Pin Din or Mini Connectors • .55 to 4.15 Cv 	www.parker.com/pneu/isomax	E
<ul style="list-style-type: none"> • Robust Spool Design • Fast Response & High Flow • Plug-in & Direct Pipe Design • 4-Way • Hazardous Duty Option • 1.9 to 12.0 Cv 	www.parker.com/pneu	E
<ul style="list-style-type: none"> • Robust Poppet & Spool Designs • 3-Way & 4-Way • Manual & Mechanical • Plunger, Roller, One-Way Tripper, Button, Hand Lever, Toggle • 1/8" NPT • .17 to .20 Cv 	www.parker.com/pneu/directair	F
<ul style="list-style-type: none"> • Robust Poppet & Spool Designs • 3-Way & 4-Way • Lever, Pedal, Treadle, Button • 1/4" NPT • .83 Cv 	www.parker.com/pneu/directair	Manual Mechanical
<ul style="list-style-type: none"> • Heavy Duty Design • 4-Way • Lever, Pedal Operated • 1/4" & 3/8" NPT • 1.3 to 2.8 Cv 	www.parker.com/pneu/42ser	F
<ul style="list-style-type: none"> • Heavy Duty Design • Bronze Body • 3-Way & 4-Way, Air Pilot Manual & Mechanical Valves • 1/4" to 1" NPTF Ports • 2.4 to 12.4 Cv 	www.parker.com/pneu	F
<ul style="list-style-type: none"> • Compliant with OSHA Standard 29 CFR 1910 • Lockout / Soft Start • 3.7 to 14.0 Cv 	www.parker.com/pneu/lockout	F
<ul style="list-style-type: none"> • Manual Valves • Lever & Button Operators • 1/8" thru 1/2" Ports • Wide Range of Sizes & Flows • .5 to 1.25 Cv 	www.parker.com/pneu/ssv	F
<ul style="list-style-type: none"> • Variety of Control Panel Options - Push Buttons - Indicators - Foot Pedals • Large Selection of Options • Two-Hand Control Conformance with EN 574 	www.parker.com/pneu/cpp	G
<ul style="list-style-type: none"> • Large Variety of Limit & Pressure Switches • Limit Switches for Standard & Heavy Duty Service • Blocking Valves for Air, Gas & Liquid Service • Threshold Sensors for Monitoring Cylinder Exhaust 	www.parker.com/pneu/limsen	Accessories
<ul style="list-style-type: none"> • Flow Controls • Check Valves • Needle Valves • Muffler & Silencers • Relief Valves • Quick Exhaust Valves • Ball Valves • Fittings • Tubing & Hose • Quick Couplings 	www.parker.com/pneu/accessories	G
<ul style="list-style-type: none"> • Model Number to Page Number Index • Safety Guide • Offer of Sale 		H





"XM" Series

Air Control Valves

Direct Acting, 1/8" Port

3-Way & 4-Way: .15 Cv

B

XM

15mm
Solenoid

Section B

www.parker.com/pneu/xm

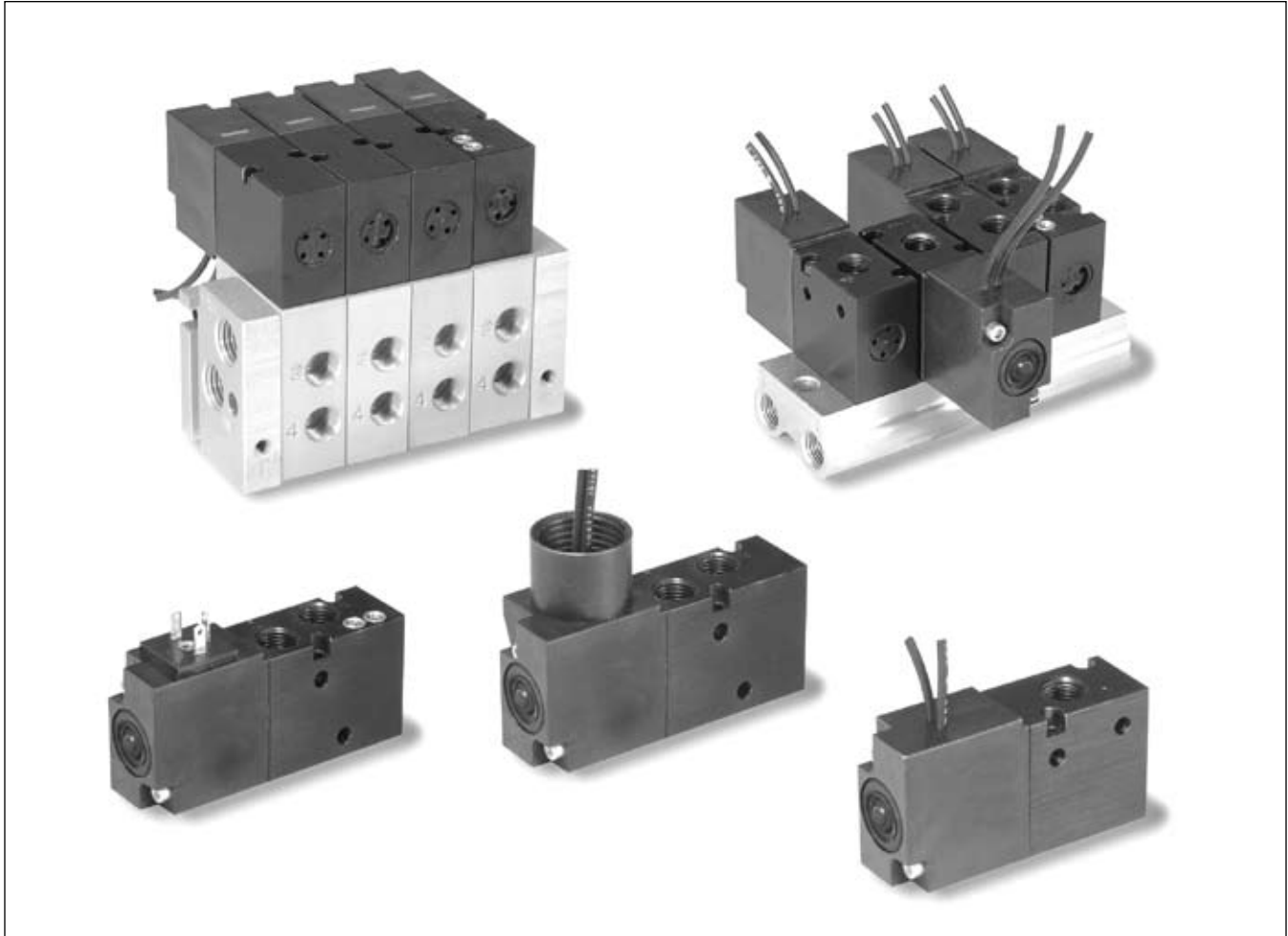

Basic Valve Functions	B2	Kits & Accessories	B9
XM Series Basic Features.....	B3	Dimensions.....	B10-B13
Common Part Numbers.....	B4		
Model Number Index.....	B5		
IEM Bar Manifolds & Subbase Manifolds.....	B6		
Manifold Ordering Information.....	B7		
Technical Information.....	B8		

BOLD ITEMS ARE MOST POPULAR.



B

XM

**15mm
Solenoid**

3-Way, 2-Position, Normally Closed

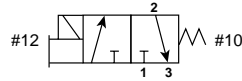

De-energized position – Solenoid #12 de-energized. Pressure at inlet port 1 blocked, outlet port 2 connected to exhaust port 3.

Energized position – Solenoid #12 energized. Pressure at inlet port 1 is connected to outlet port 2, exhaust port 3 is blocked.

3-Way, 2-Position, Normally Open

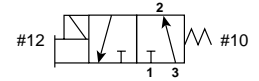

De-energized position – Solenoid #12 de-energized. Pressure at inlet port 3 connected to outlet port 2, exhaust port 1 is blocked.

Energized position – Solenoid #12 energized. Pressure at inlet port 3 blocked, outlet port 2 connected to exhaust port 1.

3-Way, 2-Position, Diverter

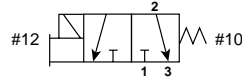

De-energized position – Solenoid #12 de-energized. Pressure at inlet port 2 connected to outlet port 3. Port 1 is blocked.

Energized position – Solenoid #12 energized. Pressure at inlet port 2 is connected to outlet port 1. Port 3 is blocked.

3-Way, 2-Position, Selector

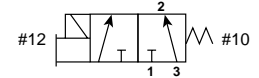

De-energized position – Solenoid #12 de-energized. Pressure at inlet port 1 is blocked. Pressure at inlet port 3 is connected to outlet port 2.

Energized position – Solenoid #12 energized. Pressure at inlet port 1 is connected to outlet port 2. Pressure at port 3 is blocked.

2-Way, 2-Position, Normally Closed

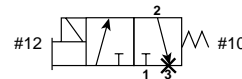

De-energized position – Solenoid #12 de-energized. Pressure at inlet port 1 blocked, port 2 is connected to port 3, which is plugged.

Energized position – Solenoid #12 energized. Pressure at inlet port 1 is connected to outlet port 2. Port 3 is blocked.

* Plug port 3.

2-Way, 2-Position, Normally Open

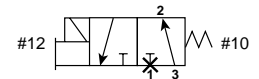

De-energized position – Solenoid #12 de-energized. Pressure at inlet port 3 is connected to outlet port 2. Port 1 is blocked.

Energized position – Solenoid #12 energized. Pressure at inlet port 3 is blocked. Port 2 is connected to port 1, which is plugged.

* Plug port 1.

4-Way, 2-Position

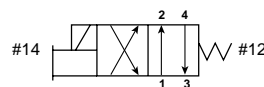

De-energized position – Solenoid #14 de-energized. Pressure at inlet port 1 connected outlet port 2. Outlet port 4 connected to exhaust port 3.

Energized position – Solenoid #14 energized. Pressure at inlet port 1 is connected to outlet port 4. Outlet port 2 connected to exhaust port 3.

4-Way, 2-Position with Flow Controls

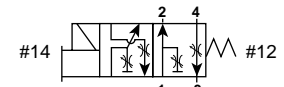

De-energized position – Solenoid #14 de-energized. Pressure at inlet port 1 connected outlet port 2. Outlet port 4 connected to exhaust port 3.

Energized position – Solenoid #14 energized. Pressure at inlet port 1 is connected to outlet port 4. Outlet port 2 connected to exhaust port 3.

Flow Controls meter exhaust from ports 2 and 4 separately into port 3.

Flow Characteristics

- 3-Way: .15 Cv
- 4-Way: .15 Cv

3-Way Operating Pressure

- 0 to 125 PSIG
- 0 to -14.7 PSIG

4-Way Operating Pressure

- -14.7 to 125 PSIG

Ports

- 1/8" NPT

Mounting

- Inline
- IEM Bar Manifold
- Subbase Valve Manifold

Solenoids

- Continuous Duty Rated
- 24" Grommet
- 15mm 3-Pin (9.4 mm Pin Spacing)
- 1/2" Conduit
- 12VDC to 240VAC

Balanced Poppet

- 3-Way N.O. & N.C.
- Diverter
- Selector
- Vacuum Option

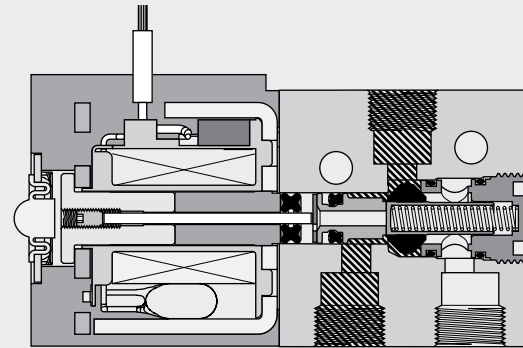

3-Way Inline Valve
Shown Energized

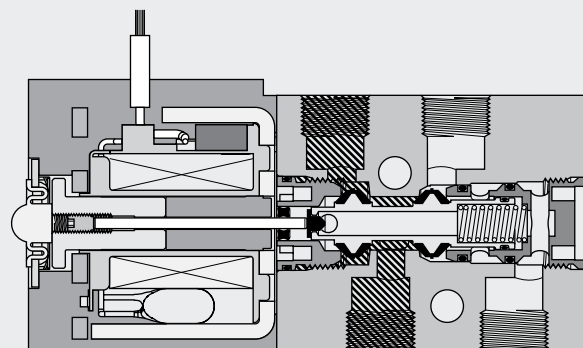

4-Way Inline Valve
Shown De-Energized

 Pressure  Exhaust

B

XM

15mm
Solenoid

B

XM

15mm Solenoid

Inline Valves

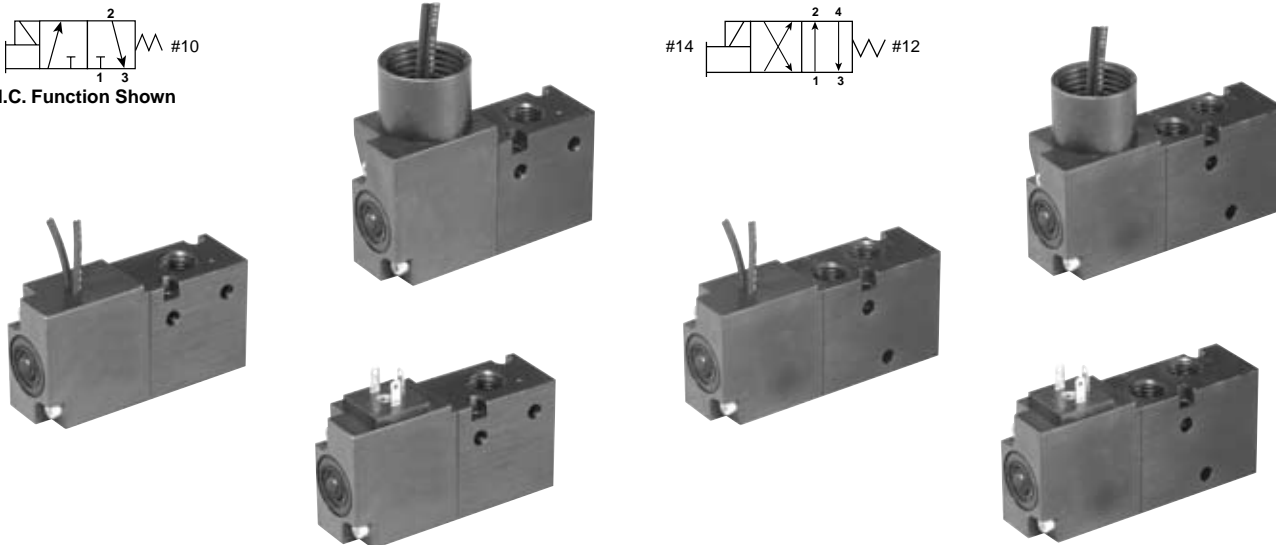
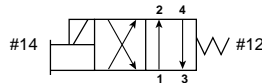
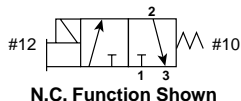

3-Way

24" Grommet	3-Pin 15mm DIN 9.4mm	1/2" Conduit / 24" Leads	Voltage
XM30NBG49A	XM30NB549A	XM30NBH49A	24VDC
XM30NBG53A	XM30NB553A	XM30NBH53A	120VAC

Note: All units with non-locking flush override.
 Can be used as N.O / N.C. / Diverter / Selector function.

4-Way

24" Grommet	3-Pin 15mm DIN 9.4mm	1/2" Conduit / 24" Leads	Voltage
XM40NBG49A	XM40NB549A	XM40NBH49A	24VDC
XM40NBG53A	XM40NB553A	XM40NBH53A	120VAC

Note: All units with non-locking flush override.

Subbase Mount

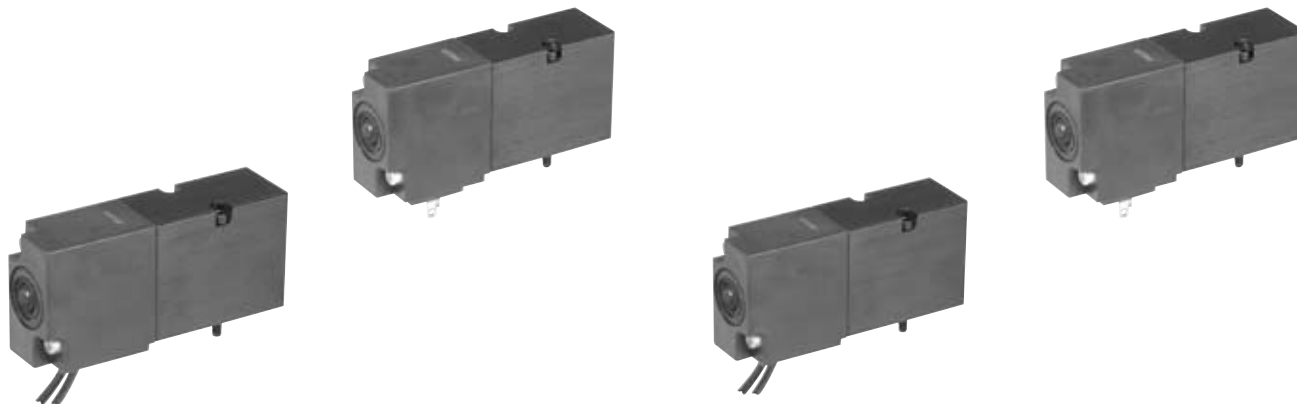
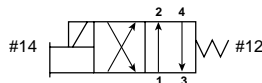
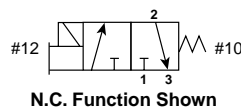

3-Way

24" Grommet	3-Pin 15mm DIN 9.4mm	Voltage
XM3VNBG49A	XM3VNB549A	24VDC
XM3VNBG53A	XM3VNB553A	120VAC

Note: All units with non-locking flush override.
 Can be used as N.O / N.C. / Diverter / Selector function.

4-Way

24" Grommet	3-Pin 15mm DIN 9.4mm	Voltage
XM4VNBG49A	XM4VNB549A	24VDC
XM4VNBG53A	XM4VNB553A	120VAC

Note: All units with non-locking flush override.



BOLD OPTIONS ARE MOST POPULAR.

XM 4 0 N B G49 — A

Operator / Function	
3-Way, Direct Operated, Single Solenoid, Spring Return	3
4-Way, Direct Operated, Single Solenoid, Spring Return	4

Engineering Level	
A	Current

Port Size / Thread Type	
1/8" NPT Inline	0*
Subbase Valve Less Base	V

* Available on IEM manifolds.

Options	
Blank	None
FO*	Flow Control

* 4-Way Valves Only.

Pilot Source / Exhaust	
Direct Operated / Standard Pressure	N*
Direct Operated / Vacuum Service	V**

* 3-Way Valve Positive Pressure,
 4-Way Valve Vacuum or Positive Pressure
 ** 3-Way Valve Vacuum Pressure.

Overrides	
Flush - Non-Locking	B

		Enclosures / Lead Length		
		Voltage		
		60Hz	50Hz	DC
542	15mm 3-Pin DIN 9.4mm	24	22	
545*	15mm 3-Pin DIN 9.4mm			12
549*	15mm 3-Pin DIN 9.4mm			24
553	15mm 3-Pin DIN 9.4mm	120	110	
G42	Grommet / Flying Leads 24"	24	22	
G45*	Grommet / Flying Leads 24"			12
G49*	Grommet / Flying Leads 24"			24
G53	Grommet / Flying Leads 24"	120	110	
G57	Grommet / Flying Leads 24"	240	220	
H42†	1/2" Conduit / Flying Leads 24"	24	22	
H45*†	1/2" Conduit / Flying Leads 24"			12
H49*†	1/2" Conduit / Flying Leads 24"			24
H53†	1/2" Conduit / Flying Leads 24"	120	110	

* Mobile Voltage Rated.

† Inline Version Only.

B
 XM
 15mm Solenoid

Notes:
Inline Valves
 Conduit Inline valves cannot be mounted to IEM or Subbase Manifolds.

B
XM
15mm Solenoid

IEM Bar Manifold Assembly

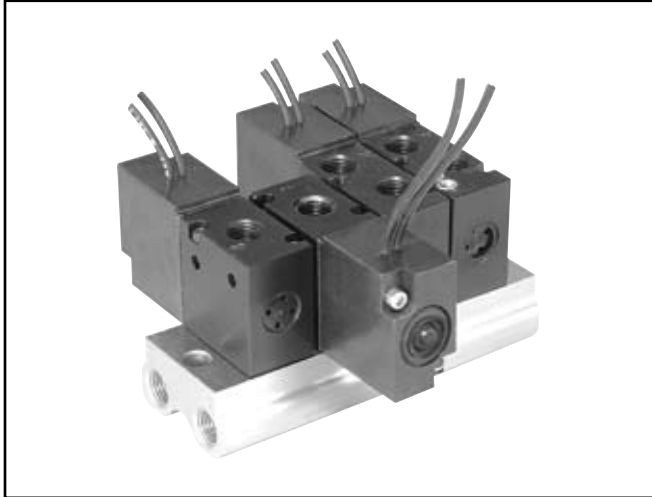

IEM Bar Manifold

Allows for mounting of 3-Way and 4-Way Inline valves on the same manifold. 3-Way Valves can be mounted on the same manifold to provide a Normally Closed or Normally Open function by rotating the valves 180°. 4-Way valves can be mounted with or without Flow Controls.

IEM Bar Manifold Assemblies consist of valves and an IEM Manifold. Valves and IEM Manifold can be ordered separately.

Subbase Manifold Assembly

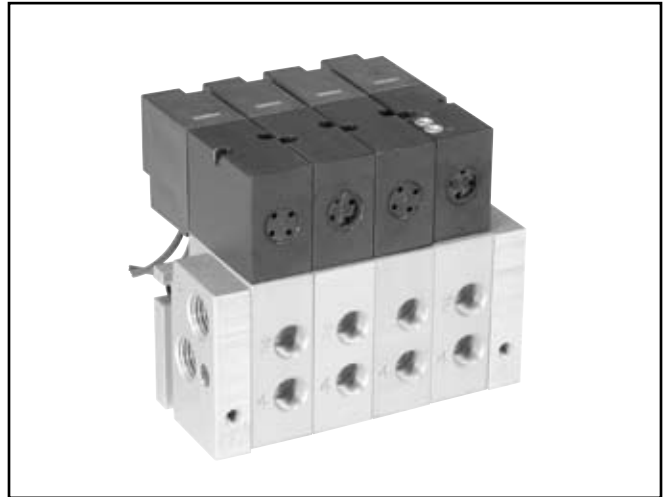

Subbase Manifold

Allows for mounting of 3-Way and 4-Way Subbase Valves can be mounted on the same manifold. 3-Way Valves can be mounted on the same manifold to provide a Normally Closed or Normally Open function through the use of port isolation kits. 4-Way valves can be mounted with or without Flow Controls.

Subbase Manifold Assemblies consist of Valves, End Plate Kit and Manifold Subbase Kits. Valves, End Plate Kit and Manifold Subbase Kits can be ordered separately.



IEM Bar Manifold (NPT)

PSMXNXN##NP

– stations 02 to 12



End Plate Kit (NPT)

PSXM31010P



Manifold Subbase Kit (NPT)

PSXM530CP

How to Order Manifold Assemblies

BOLD OPTIONS ARE MOST POPULAR.

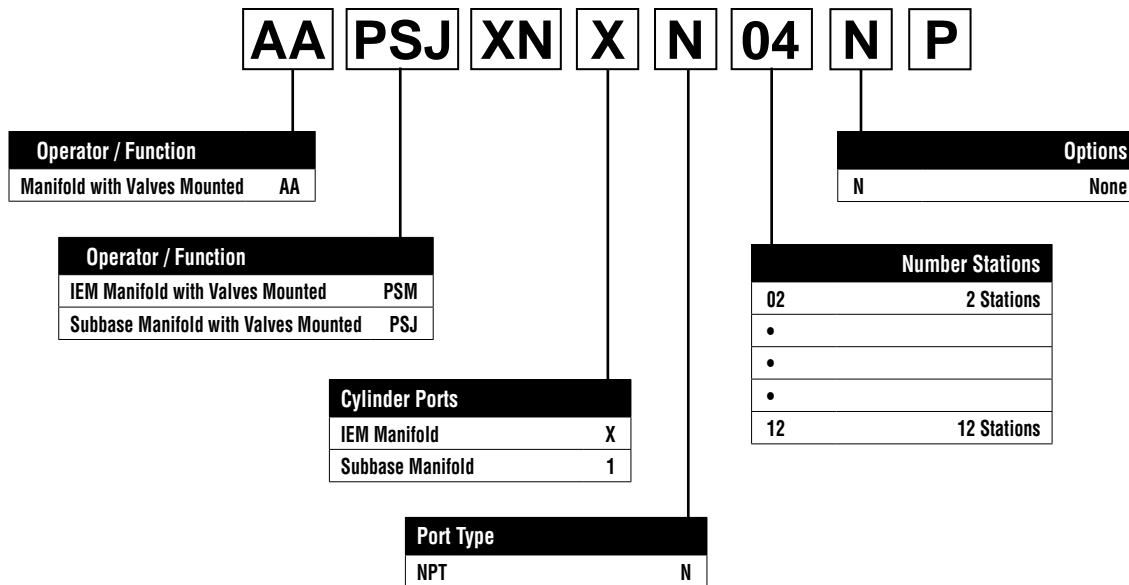

B

XM

15mm Solenoid

IEM Bar Manifold Assembly

First line item describes IEM Assembly. Subsequent line items listed identify each station in the Manifold starting with Station Number 1.

Subbase Manifold Assembly

First line item describes Subbase Assembly. Subsequent line items listed identify each station in the Manifold starting with Station Number 1.

Manifold Assembly Ordering Example

Item	Qty	Part Number
001	1	AAPSMXNXN04NP
002	2	XM30NBG49A - Station 1, 2 - Normally Closed
003	1	XM40NBG49A - Station 3
004	1	XM40NBG49F0A - Station 4

Notes: When ordering Add-A-Folds, list valves left to right when looking at the Port 1/3 side of the manifold. All 3-Way valves will be assembled as 3-Way N.C. valves.

Subbase Manifold Ordering Example

Item	Qty	Part Number
001	1	AAPSJXN1N04NP
002	2	XM3VNBG49A - Station 1, 2 - Normally Closed
003	1	XM4VNBG49A - Station 3
004	1	XM4VNBG49F0A - Station 4

Notes: When ordering Add-A-Folds, list valves left to right when looking at the Port 2/4 side of the manifold. All 3-Way valves will be assembled as 3-Way N.C. valves. Isolator Discs are required for N.O. functions

Component Ordering Example

Item	Qty	Part Number
001	1	PSMXNXN04NP (IEM Kit)
002	2	XM30NBG49A (Valve)
003	1	XM40NBG49A (Valve)
004	1	XM40NBG49F0A (Valve)

Component Ordering Example

Item	Qty	Part Number
001	1	PSXM31010P (End Plate Kit)
002	4	PSXM530CP (Subbase Kit)
003	2	XM3VNBG49A (Valve)
004	1	XM4VNBG49A (Valve)
005	1	XM4VNBG49F0A (Valve)



B

XM

15mm
Solenoid

Inline Valve on IEM Bar Manifold Assembly

IEM Bar Manifold Assembly's are assembled by adding Inline Valves to an IEM Bar Manifold. O-rings are installed at each valve station in the counterbore on the top of the manifold. Valves are installed with 2 mounting screws. For 3-Way N.C. valve operation, line up the solenoid end of the Valve with Port 1 on the Manifold. For 3-Way N.O. operation, line up the solenoid end of the valve with Port 3 on the manifold. For 4-Way valve operation, line up the Solenoid end of the valve with Port 1 on the manifold. If manifolds are factory assembled, all 3-Way valves are N.C. To convert from N.C. to N.O. operation, remove valve from the base and place valve 180° from the original position with the solenoid end lined up with the 3-Port on the manifold.

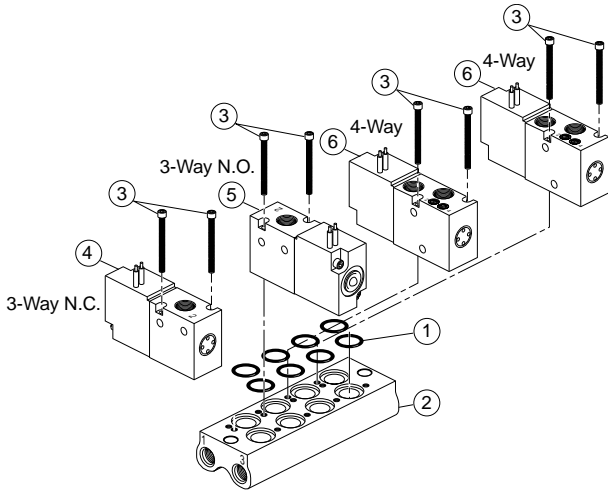

Subbase Valve and Manifold Assembly

Subbase Manifold Assembly's are assembled by adding tie rods and manifold bases to the end plate kit of the subbase end plate kit as shown below. Valves are added to each subbase per manifold design. 4-Way and 3-Way valves are mounted with Solenoids Coils facing away from subbase delivery ports 2 and 4. For 3-Way N.O. Functions, valves must be isolated from the other 3-Way N.C. and 4-Way valves on the manifold. This is achieved by placing port isolator discs in between the subbase of the first 3-Way N.O. Valve and the subbase of the last 3-Way N.C. or 4-Way valve in the Subbase Manifold. Inlet pressure is connected to Port 3 of the manifold for the 3-Way N.O. valves. Inlet pressure is connected to the Port 1 of the manifold for the 3-Way N.C. and 4-Way valves. Separate Inlet Pressure Ports and Exhaust Ports are required for N.O. and N.C. 3-way function valves.

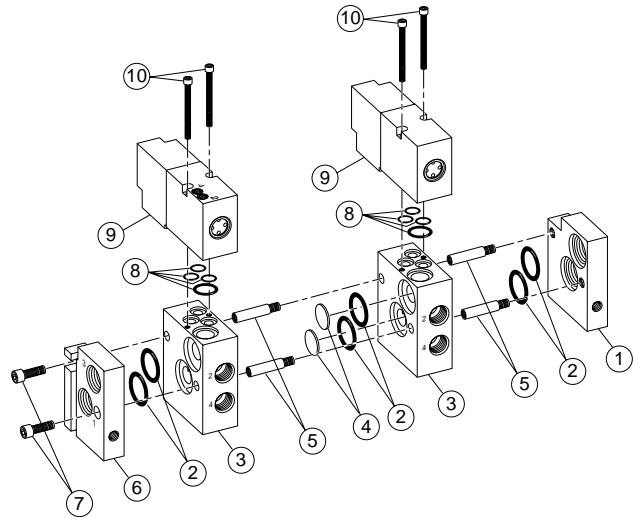

Performance Information

Code	Electrical				Holding Current (Amps)	Flow		Seals
	Voltage		Power Consumption (W / VA)	Cv Chart				
	AC	DC		3-Way		4-Way		
	60Hz	50Hz						
42	24	22	—	4.8VA	.200	.15	.15	Buna N
45*	—	—	12	4.5W	.375	.15	.15	
49*	—	—	24	4.5W	.188	.15	.15	
53	120	110	—	4.32VA	.036	.15	.15	
57	240	220	—	4.32VA	.018	.15	.15	
Note: Voltage Tolerance: +10 / -15%						Cv tested per ANSI / (NFPA) T3.21.3		

* Mobile Voltage, +25/-30%

Response Time

Code	Voltage	0 Cu. In. Test Chamber		12 Cu. In. Test Chamber	
		Fill	Exhaust	Fill	Exhaust
49	24VDC	.011	.007	.240	.384
53	120VAC	.011	.020	.240	.384

Average Fill Time (Seconds): With 100 PSIG supply, time required to fill from 0-90 PSIG and exhaust from 100 PSIG to 10 PSIG is measured from instant of energizing, or de-energizing solenoid. Times shown are average.

Tested per ANSI / (NFPA) T3.21.8.

Operating Pressure

Function / Pilot Source	Minimum	Maximum
3-Way, N	0 PSIG	125 PSIG
3-Way, V	Vacuum	25 PSIG
4-Way, N	Vacuum	125 PSIG

Temperature Rating

32°F to 125°F (0°C to 50°C)



Blanking Plate



Kit Number	
Part Number	Description
PSXM8310P	Subbase Blank Kit

Subbase Kit includes: (1) Plate, (3) Screws, (4) Gaskets
 Fits Subbase or IEM type Manifold.

IEM Valve / Manifold O-ring Kit



Part Number	Description
PSXM2186P	IEM Valve / Manifold O-ring Kit

Mounting Bracket - Inline Valve



Part Number	Description
PSXM8288P	Mounting Bracket

Subbase Valve / Manifold Bolt Kit

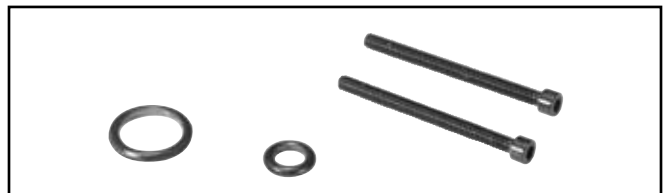

Part Number	Description
PSXM8100P	Subbase Valve / Manifold Bolt Kit

Isolator Plugs - Subbase Manifold



Part Number	Description
PSXM40900P	Isolation Plugs

Plug-in Electrical Connectors - 9.4mm



Indication	Voltage	Unwired Plug	Plug with 6' Lead
None	N/A	PESC10	PESC12
LED & Suppression	12/24V	PESC2020B	PESC2220B
	120VAC	PESC2001F	PESC2201F

B
 XM
 15mm Solenoid

B

XM

15mm Solenoid

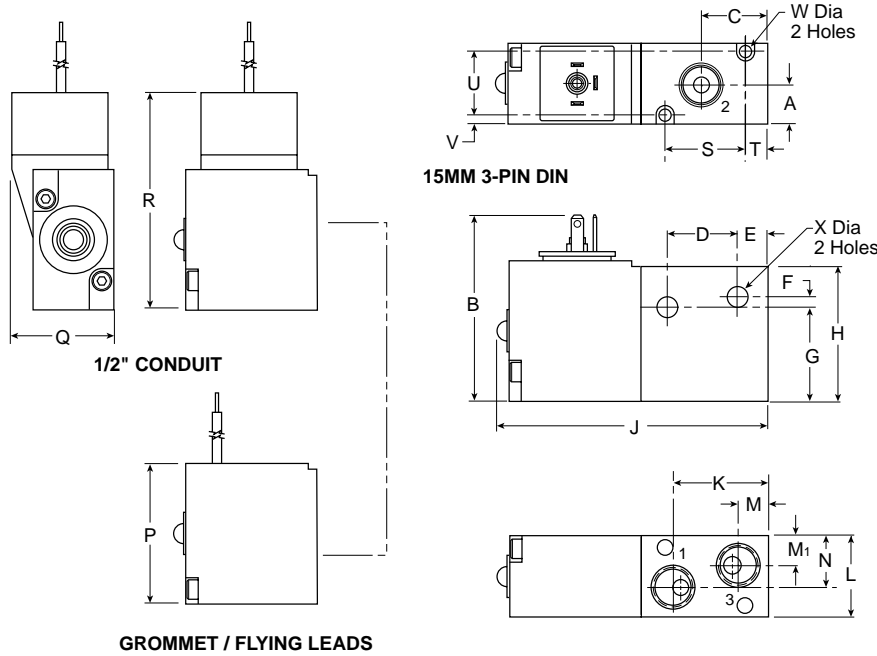

XM 3-Way Inline

A .38 (10)	B 1.69 (43)	C .62 (16)	D .66 (17)	E .28 (7.0)
F .10 (2.5)	G .87 (22)	H 1.25 (32)	J 2.50 (64)	K .87 (22)
L .75 (19)	M .28 (7.0)	M₁ .28 (7.0)	N .48 (12)	P 1.32 (34)
Q .98 (24.9)	R 2.10 (53)	S .75 (19)	T .21 (5.4)	U .59 (15)
V .08 (2.0)	W .11 (2.9)	X .16 (4.0)		

Inches (mm)

Valve Weight

Grommet.....	4 oz (.11 Kg)
DIN	4 oz (.11 Kg)
Conduit	5 oz (.14 Kg)

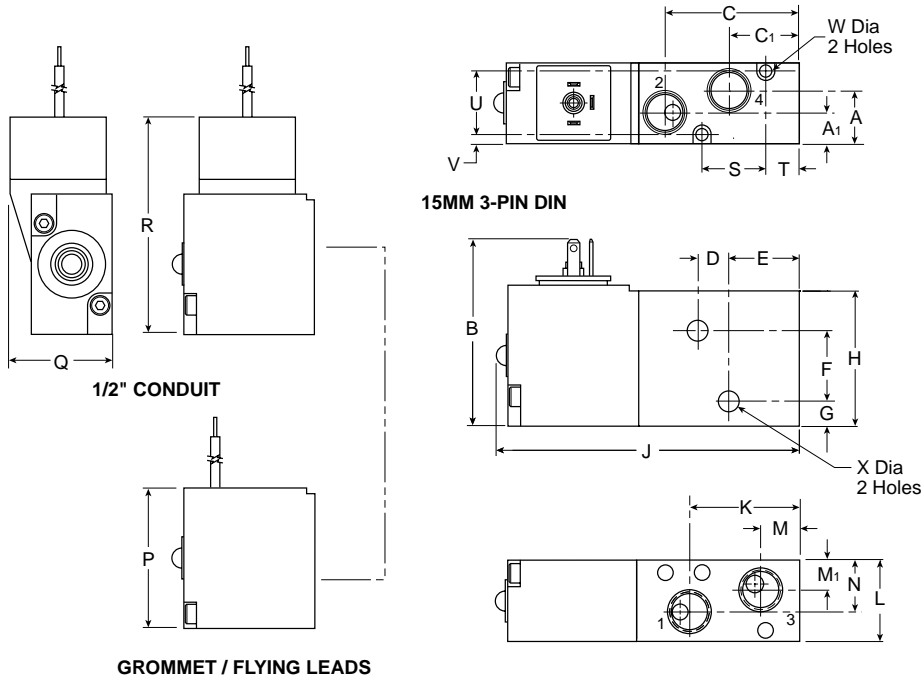

XM 4-Way Inline

A .48 (12)	A₁ .28 (6.9)	B 1.69 (43)	C 1.23 (31)	C₁ .64 (16)
D .24 (6.5)	E .68 (17)	F .65 (16.5)	G .22 (5.6)	H 1.25 (32)
J 2.80 (71)	K 1.01 (26)	L .75 (19)	M .36 (9.1)	M₁ .28 (7.1)
N .48 (12)	P 1.32 (34)	Q .98 (25)	R 2.10 (53)	S .59 (15)
T .32 (8.0)	U .59 (15)	V .08 (2.0)	W .11 (2.9)	X .16 (4.0)

Inches (mm)

Valve Weight

Grommet.....	4.3 oz (.12 Kg)
DIN	4.3 oz (.12 Kg)
Conduit	5.3 oz (.15 Kg)

XM 4-Way Inline with Flow Controls

A	A ₁	B	C	C ₁
.48 (12)	.28 (6.9)	1.69 (43)	1.23 (31)	.64 (16)
D	E	F	G	H
.24 (6.5)	.68 (17)	.65 (16.5)	.22 (5.6)	1.25 (32)
J	K	L	M	M ₁
2.80 (71)	1.01 (26)	.75 (19)	.36 (9.1)	.28 (7.1)
N	P	Q	R	S
.48 (12)	1.32 (34)	.98 (25)	2.10 (53)	.59 (15)
T	U	V	W	X
.32 (8.0)	.59 (15)	.08 (2.0)	.11 (2.9)	.16 (4.0)

Inches (mm)
 Valve Weight
 Grommet..... 4.3 oz (.12 Kg)
 DIN 4.3 oz (.12 Kg)
 Conduit..... 5.3 oz (.15 Kg)

B
 XM
 15mm Solenoid

Mounting Bracket Dimensions

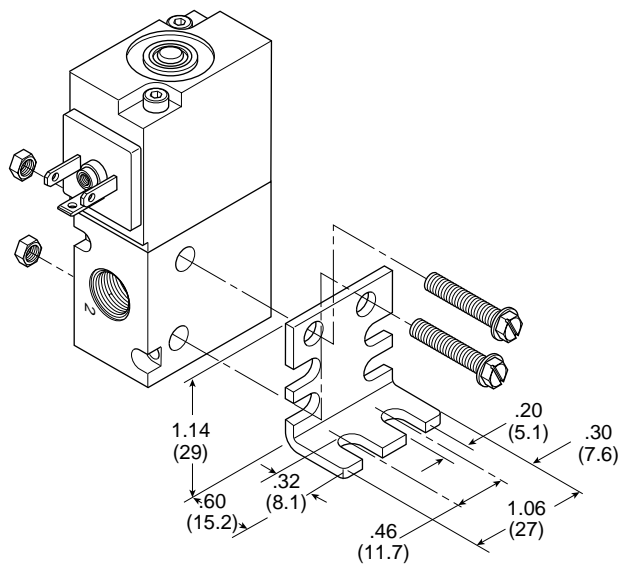

B

XM

**15mm
 Solenoid**

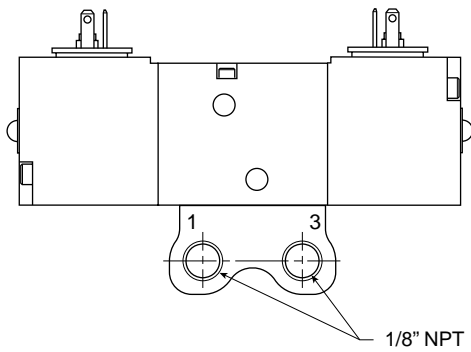
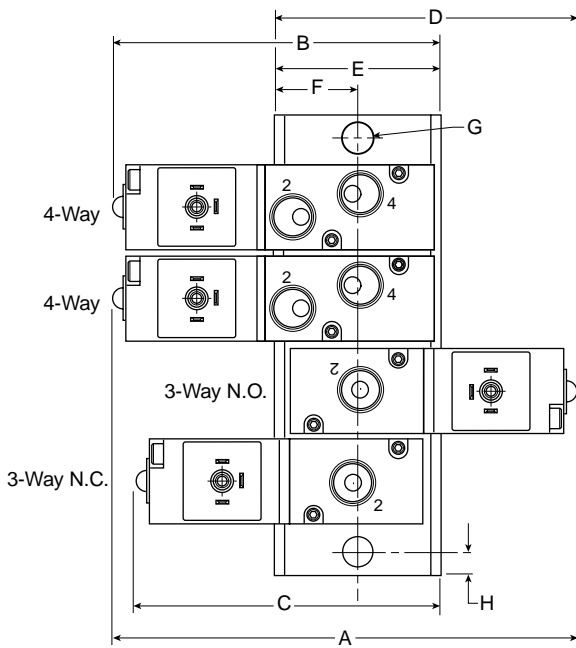

XM IEM Manifold

A	B	C	D	E
4.04 (103)	2.86 (73)	2.67 (68)	2.67 (68)	1.47 (37)
F	G	H	J	L
.74 (19)	Ø .28 (7.0)	.20 (5.0)	2.11 (54)	.79 (20)
M	N	P	Q	
.80 (20.5)	.48 (12)	.88 (22)	.44 (11)	

Inches (mm)

Manifold Weight

2 Station 2.5 oz (.07 Kg)
 Each Additional 1 oz (.03 Kg)

Valve Weight

3-Way 4 oz (.11 Kg)
 4-Way 4.3 oz (.12 Kg)

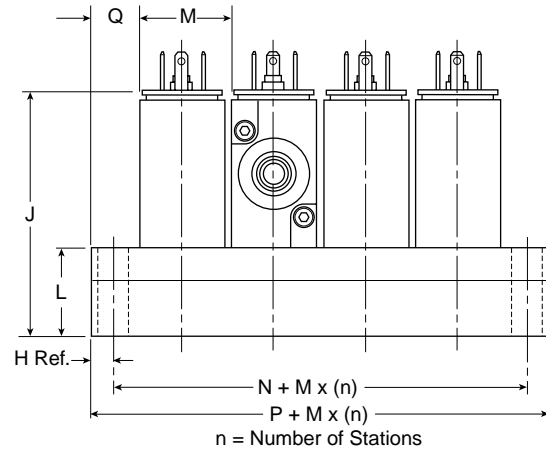

B
 XM
 15mm Solenoid

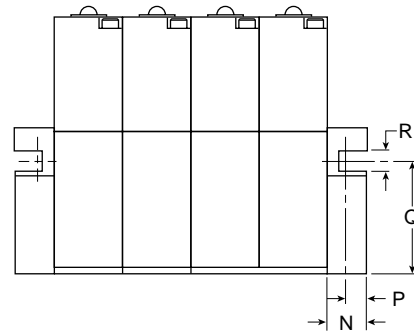

XM Subbase

A 1.62 (41)	B 2.00 (51)	C 1.58 (40)	D .92 (23)	E .85 (22)
F 1.19 (30)	G .61 (16)	H 1.26 (32)	J 1.70 (43)	K 3.25 (83)
L 2.85 (72)	M .75 (19)	N .44 (11)	P .28 (7.0)	Q 1.25 (32)
R .22 (5.6)	S .44 (11)	T .88 (22)	U .51 (13)	

Inches (mm)

Subbase Weight

Single Subbase 3.2 oz (.09 Kg)
 End Plates 3.2 oz (.09 Kg)

Valve Weight

3-Way 3.7 oz (.10 Kg)
 4-Way 4.6 oz (.13 Kg)

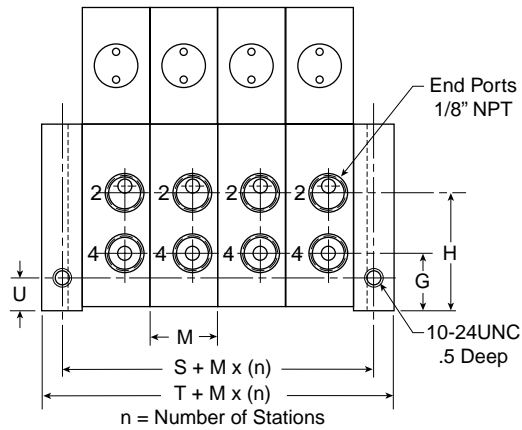
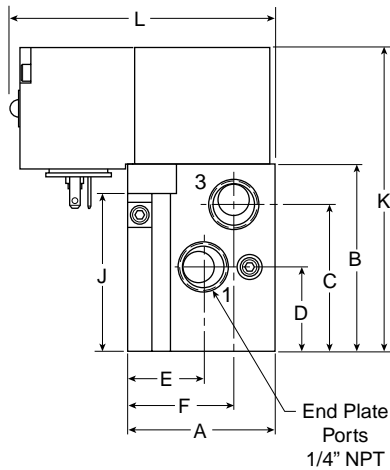

n = Number of Stations

Notes

B

XM

15mm
Solenoid



15mm Solenoid Valve

Manifold and Subbase

B

XM

15mm Solenoid

Section B

www.parker.com/pneu/15mm

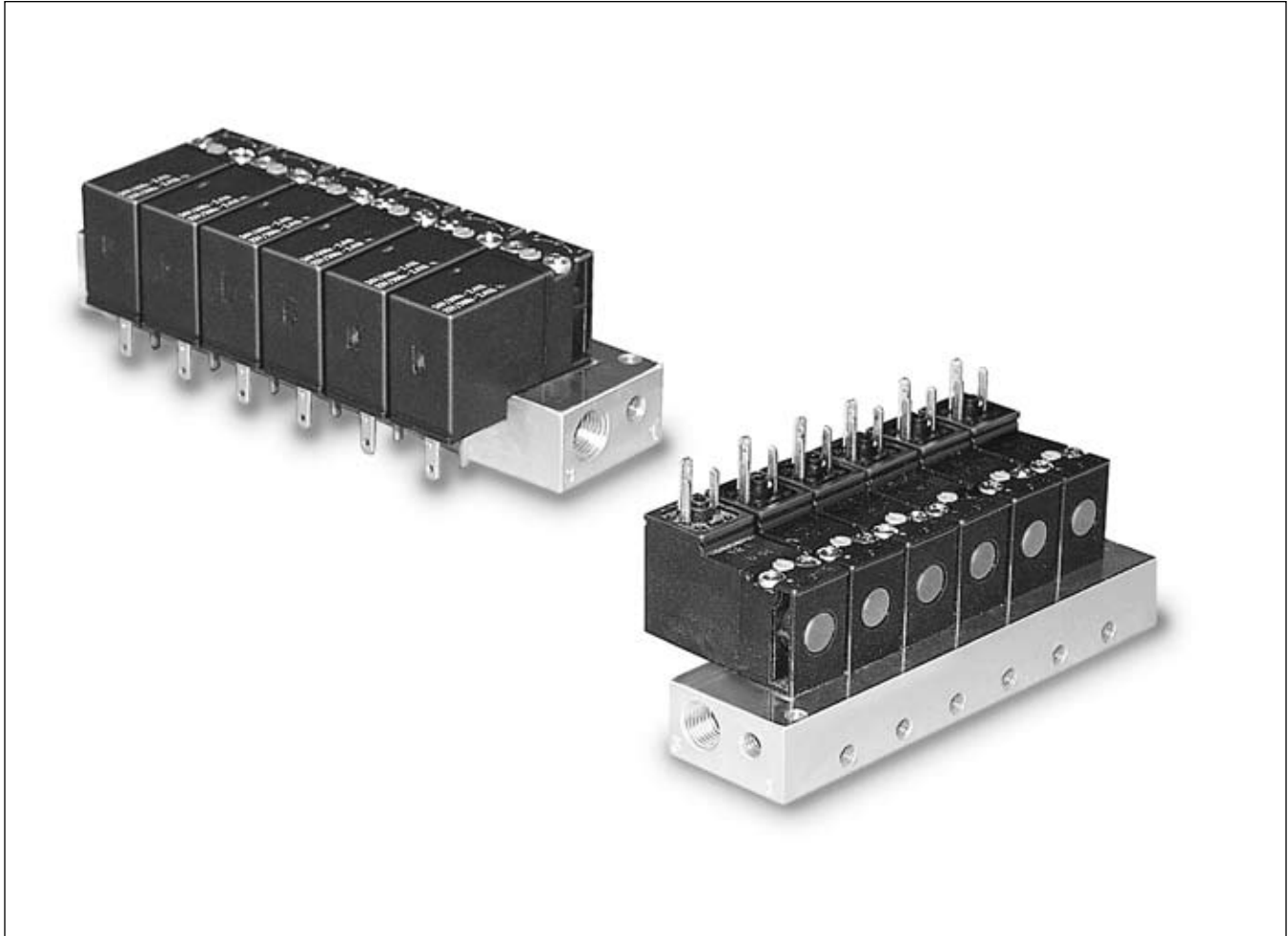

Features	B16
Model Selection	
Manifolds	B17
Subbase	B18
Solenoid Kits	B19
Electrical Connectors	B20

BOLD ITEMS ARE MOST POPULAR.



**B**

XM

15mm
Solenoid

Features

- Compact and Simple Design
- Utilizes 15mm Solenoid Operators
- Manifold Allows Mounting of Normally Open and Normally Closed Operators Simultaneously
- Up to 20 Stations Available

Specifications

Operating Pressure:

Vacuum to 145 PSIG
(Vacuum to 10 bar)

Operating Temperature:

5° to 140°F
(-15° to 60°C)

Materials:

Manifold: Aluminum
Solenoid: Glass Filled Polyamide

Solenoids:

- 15mm Low Watt Solenoids are UL Certified and Approved to be CE Marked
- Wide Range of Voltages Available

Applications

- Piloting for Process Control Valves
 - Pharmaceutical Equipment
 - Waste Water Treatment Systems
 - Food Processing
 - Chemical Batching
- Industrial Laundry Equipment
- Paint Spray & Dyeing Equipment
- Textile Winding Applications
- Vacuum and Conveyor Applications

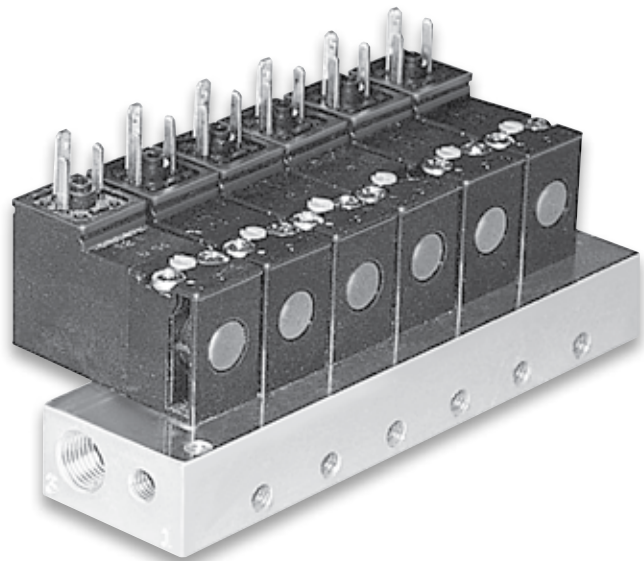
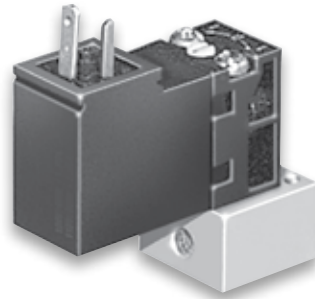



Manifold - Pins Down

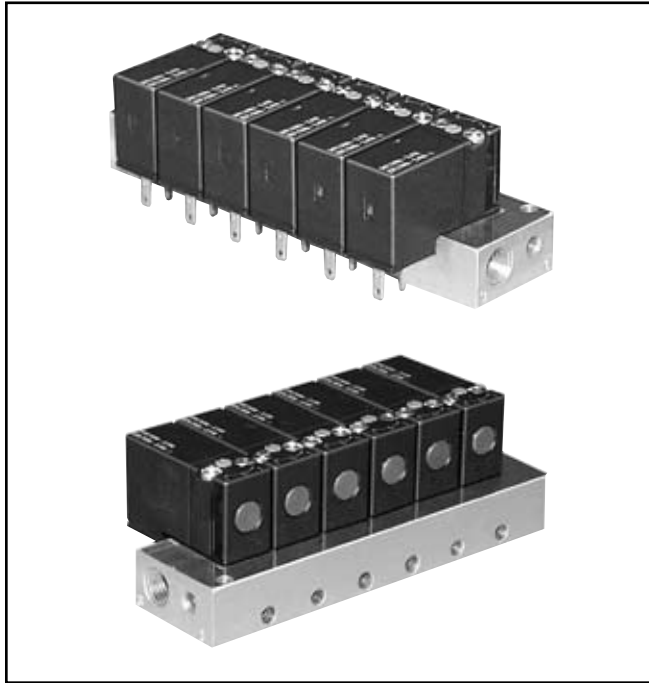

Manifold - Pins Up

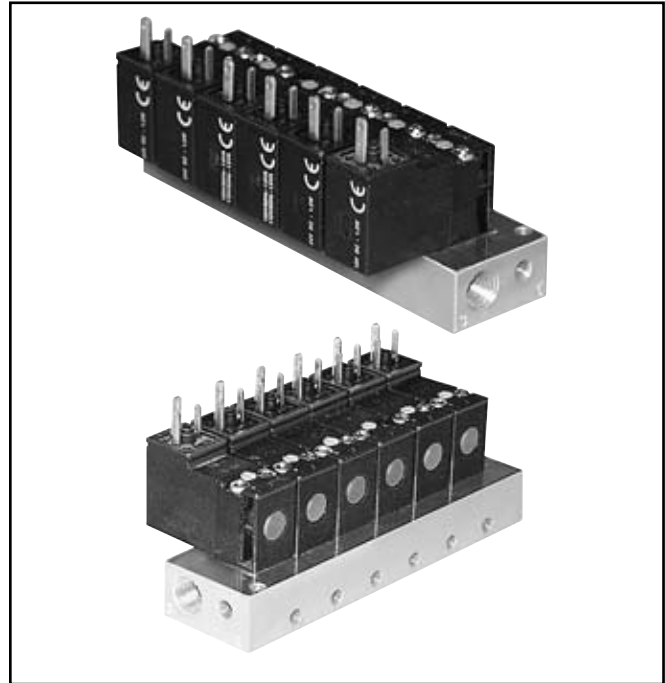

B

XM

15mm
 Solenoid

Manifold Dimensions

Special mounting considerations must be made for connector assembly clearance when mounting solenoid valves with pins down.

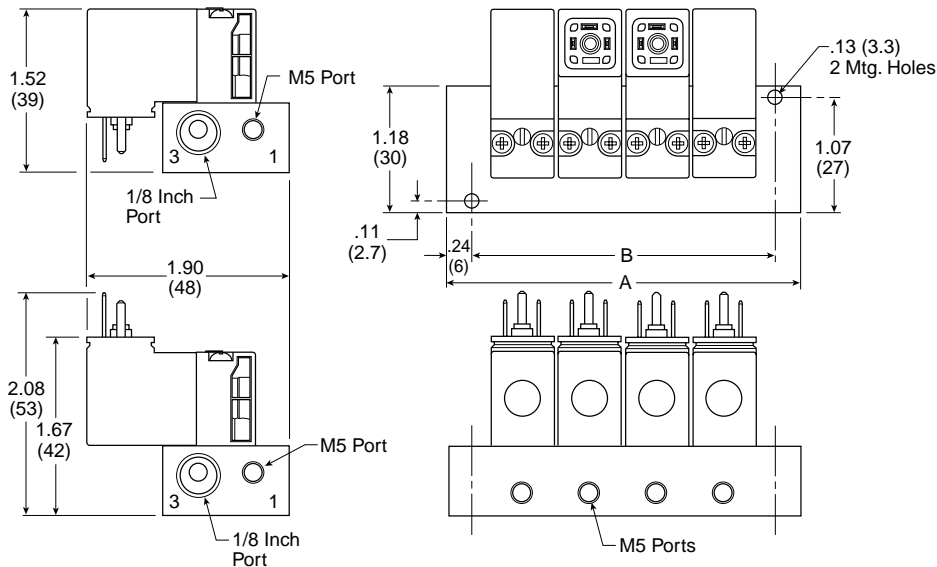

Number of Stations	Dim. A	Dim.B
2	2.04 (52)	1.57 (40)
3	2.68 (68)	2.20 (56)
4	3.31 (84)	2.83 (72)
5	3.94 (100)	3.46 (88)
6	4.57 (116)	4.09 (104)
7	5.20 (132)	4.72 (120)
8	5.83 (148)	5.35 (136)
9	6.46 (164)	5.98 (152)
10	7.09 (180)	6.61 (168)
11	7.72 (196)	7.24 (184)
12	8.35 (212)	7.87 (200)
13	8.98 (228)	8.50 (216)
14	9.61 (244)	9.13 (232)
15	10.23 (260)	9.76 (248)
16	10.87 (276)	10.39 (264)
17	11.50 (292)	11.02 (280)
18	12.13 (308)	11.65 (296)
19	12.76 (324)	12.28 (312)
20	13.39 (340)	12.91 (328)



Subbase

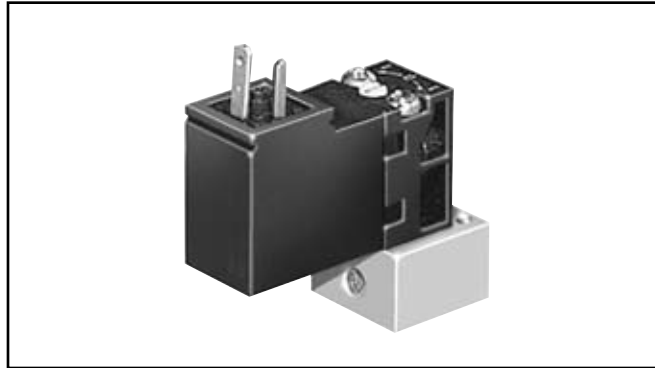

Subbase Dimensions

Pins up only.

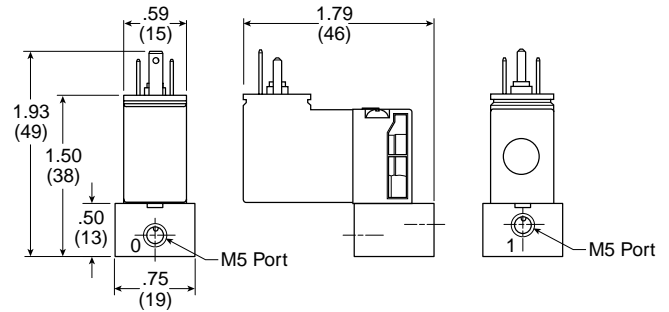

B
 XM
 15mm Solenoid

Model Number Index

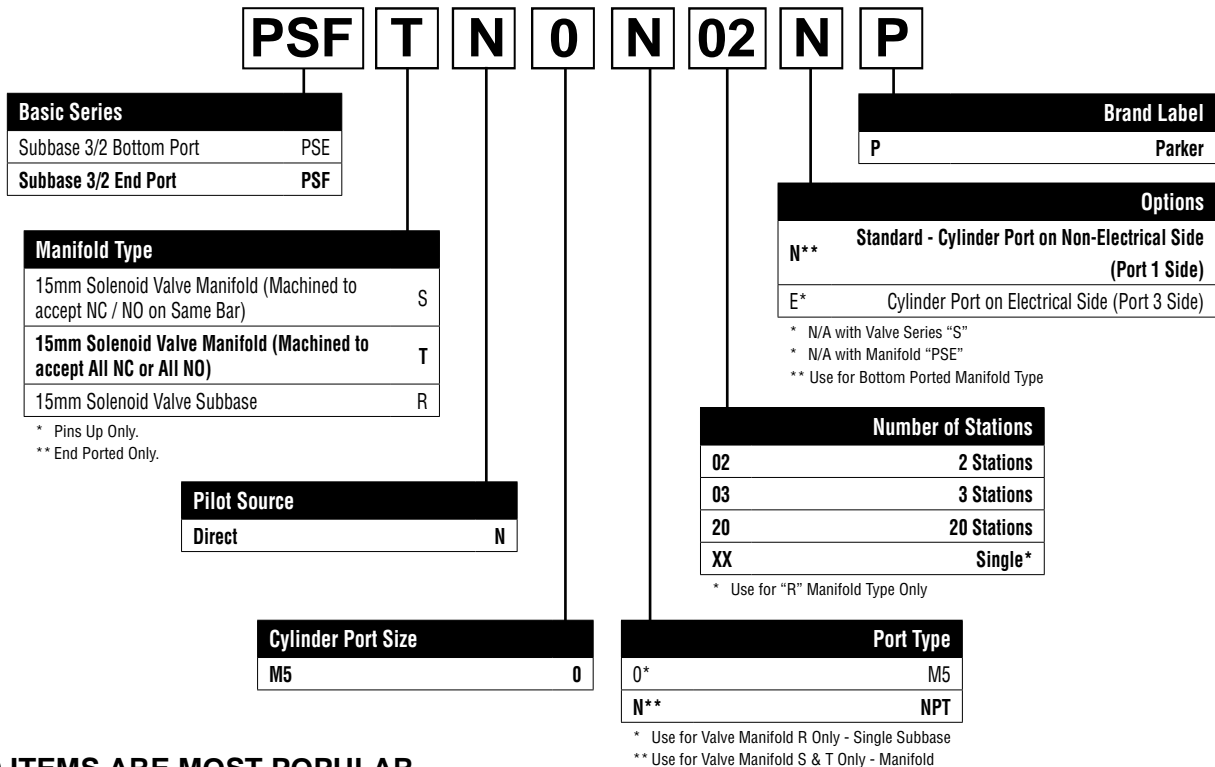

BOLD ITEMS ARE MOST POPULAR.

Examples:

- PSFTN0N16EP - End Port Manifold - Cyl Ports and Electrical on Same Side
- PSESN0N10NP - Bottom Port Manifold - N/C and N/O can be Interchanged
- PSFTN0N10NP - End Port Manifold - Cyl Ports and Electrical are Opposite





15mm Solenoid Kit Information

3/2 Normally Non-passing (NNP) /
Normally Closed (NC) Valves

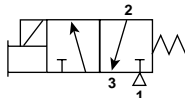

3/2 Normally Passing (NP) /
Normally Open (NO) Valves

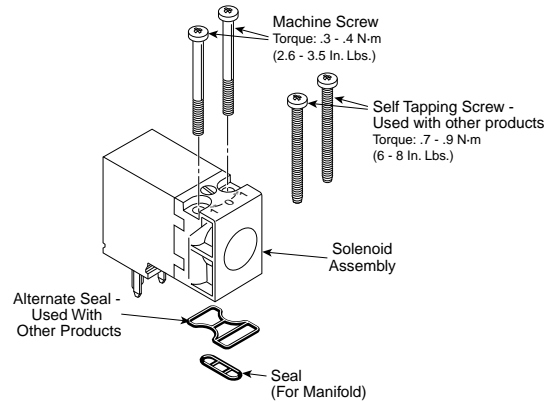
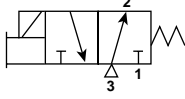

NC (NNP) Solenoids / Kits

Kit No.	* Override	## Voltage (S = Standard, O = Optional, — = N/A)				
		42 (24VAC)	45 (12VDC)	49 (24VDC)	53 (120VAC)	57 (230VAC)
PS2982*##P Pins: UP NC / NNP 1.2W / 1.6VA	B (Non-lock, Flush)	O	O	S	S	O
	C (Lock, Flush)	O	O	S	S	O
	D (Non-lock, Ext)	—	—	O	O	—
PS3541*##P Pins: DOWN NC / NNP 1.8W / 2.4VA	B (Non-lock, Flush)	O	O	S	S	—
	C (Lock, Flush)	O	O	S	S	—
	D (Non-lock, Ext)	—	—	O	O	—
	E (Lock, Ext)	—	—	O	O	—
PS3441*##P Pins: DOWN NC / NNP 1.2W / 1.6VA	B (Non-lock, Flush)	O	O	O	O	O
	C (Lock, Flush)	O	O	O	O	O
PS3202*##P Pins: UP NO / NP 1.2W / 1.6VA	B (Non-lock, Flush)	O	O	S	S	—

* Override

Voltage

BOLD ITEMS ARE MOST POPULAR.

Technical Data

Electrical Interface Per:

Din 43650 Form C (EN175301-803C)

Pneumatic Interface Per:

Afnor E 0652 110 N

Protection:

IP65 (Washdown)

Air Flow:

Standard Flow 0.033 Cv (33 Lpm) (1.2W) (1.6VA)

High Flow 0.05 Cv (50 Lpm) (1.8W) (2.4VA)

Operating Temperature:

Standard Flow: 5°F to 140°F (-15°C to 60°C)

High Flow: 5°F to 122°F (-15°C to 50°C)

Mobile Applications (47 & 48 Voltage Options):

-40°F to 158°F (-40°C to 70°C)

Operating Pressure:

Vacuum to 145 PSIG (Vacuum to 10 bar)

Storage Temperature:

All Applications: -40°F to 158°F (-40°C to 70°C)

Voltage Tolerance:

All Voltages Except 47 & 48: Rated Voltage +10% / -15%

Options 47 & 48: Rated Voltage +25% / -30%

Materials

Valve:

Body: Glass Filled Polyamide

Internal Metal Parts: Steel

Screws: Steel

Bottom Plug: Thermoplastic

Poppet Seals: Nitrile for Standard, Fluorocarbon for Mobile





Female Electrical Connectors

15mm 3-Pin DIN 43650C (Use with Enclosure "5")

B

XM

**15mm
 Solenoid**

Connector	Connector with Cord	Description
PS2932BP	PS2932HBP 18 Inches	Unlighted
PS2932BP	PS2932JBP 6 Feet	Unlighted
PS294675BP	PS2946J75BP* 6 Feet	Light – 12VAC or DC
PS294679BP	PS2946J79BP* 6 Feet	Light – 24VAC or DC
PS294683BP	PS2946J83BP* 6 Feet	Light – 110/120VAC
PS294687BP	N/A	Light – 240/230VAC

* LED with surge suppression.

Note: Max ø6.5mm cable size required for connector w/o 6' (2m) cord.
 IP65 rated when properly installed.

Engineering Data:

- Conductors: 2 Poles Plus Ground
- Cable Range (Connector Only): 4 to 6mm (0.16 to 0.24 Inch)
- Contact Spacing: 8mm

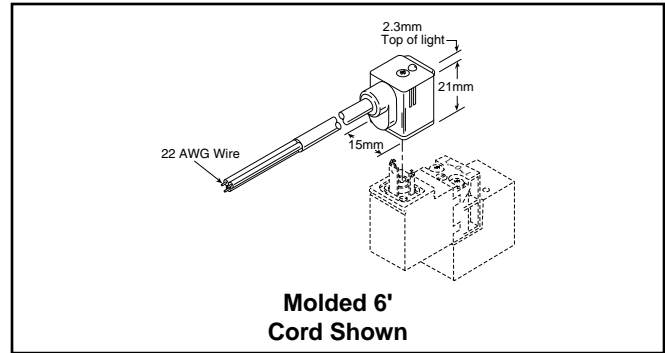

Safety Guide For Selecting And Using Pneumatic Division Products And Related Accessories

WARNING:

FAILURE OR IMPROPER SELECTION OR IMPROPER USE OF PNEUMATIC DIVISION PRODUCTS, ASSEMBLIES OR RELATED ITEMS ("PRODUCTS") CAN CAUSE DEATH, PERSONAL INJURY, AND PROPERTY DAMAGE. POSSIBLE CONSEQUENCES OF FAILURE OR IMPROPER SELECTION OR IMPROPER USE OF THESE PRODUCTS INCLUDE BUT ARE NOT LIMITED TO:

- Unintended or mistimed cycling or motion of machine members or failure to cycle
- Work pieces or component parts being thrown off at high speeds.
- Failure of a device to function properly for example, failure to clamp or unclamp an associated item or device.
- Explosion
- Suddenly moving or falling objects.
- Release of toxic or otherwise injurious liquids or gasses.

Before selecting or using any of these Products, it is important that you read and follow the instructions below.

1. GENERAL INSTRUCTIONS

- 1.1. Scope:** This safety guide is designed to cover general guidelines on the installation, use, and maintenance of Pneumatic Division Valves, FRLs (Filters, Pressure Regulators, and Lubricators), Vacuum products and related accessory components.
- 1.2. Fail-Safe:** Valves, FRLs, Vacuum products and their related components can and do fail without warning for many reasons. Design all systems and equipment in a fail-safe mode, so that failure of associated valves, FRLs or Vacuum products will not endanger persons or property.
- 1.3. Relevant International Standards:** For a good guide to the application of a broad spectrum of pneumatic fluid power devices see: ISO 4414:1998, Pneumatic Fluid Power – General Rules Relating to Systems. See www.iso.org for ordering information.
- 1.4. Distribution:** Provide a copy of this safety guide to each person that is responsible for selection, installation, or use of Valves, FRLs or Vacuum products. Do not select, or use Parker valves, FRLs or vacuum products without thoroughly reading and understanding this safety guide as well as the specific Parker publications for the products considered or selected.
- 1.5. User Responsibility:** Due to the wide variety of operating conditions and applications for valves, FRLs, and vacuum products Parker and its distributors do not represent or warrant that any particular valve, FRL or vacuum product is suitable for any specific end use system. This safety guide does not analyze all technical parameters that must be considered in selecting a product. The user, through its own analysis and testing, is solely responsible for:
 - Making the final selection of the appropriate valve, FRL, Vacuum component, or accessory.
 - Assuring that all user's performance, endurance, maintenance, safety, and warning requirements are met and that the application presents no health or safety hazards.
 - Complying with all existing warning labels and / or providing all appropriate health and safety warnings on the equipment on which the valves, FRLs or Vacuum products are used; and,
 - Assuring compliance with all applicable government and industry standards.
- 1.6. Safety Devices:** Safety devices should not be removed, or defeated.
- 1.7. Warning Labels:** Warning labels should not be removed, painted over or otherwise obscured.
- 1.8. Additional Questions:** Call the appropriate Parker technical service department if you have any questions or require any additional information. See the Parker publication for the product being considered or used, or call 1-800-CPARKER, or go to www.parker.com, for telephone numbers of the appropriate technical service department.

2. PRODUCT SELECTION INSTRUCTIONS

- 2.1. Flow Rate:** The flow rate requirements of a system are frequently the primary consideration when designing any pneumatic system. System components need to be able to provide adequate flow and pressure for the desired application.
- 2.2. Pressure Rating:** Never exceed the rated pressure of a product. Consult product labeling, Pneumatic Division catalogs or the instruction sheets supplied for maximum pressure ratings.
- 2.3. Temperature Rating:** Never exceed the temperature rating of a product. Excessive heat can shorten the life expectancy of a product and result in complete product failure.
- 2.4. Environment:** Many environmental conditions can affect the integrity and suitability of a product for a given application. Pneumatic Division products are designed for use in general purpose industrial applications. If these products are to be used in unusual circumstances such as direct sunlight and/or corrosive or caustic environments, such use can shorten the useful life and lead to premature failure of a product.
- 2.5. Lubrication and Compressor Carryover:** Some modern synthetic oils can and will attack nitrile seals. If there is any possibility of synthetic oils or greases migrating into the pneumatic components check for compatibility with the seal materials used. Consult the factory or product literature for materials of construction.
- 2.6. Polycarbonate Bowls and Sight Glasses:** To avoid potential polycarbonate bowl failures:
 - Do not locate polycarbonate bowls or sight glasses in areas where they could be subject to direct sunlight, impact blow, or temperatures outside of the rated range.
 - Do not expose or clean polycarbonate bowls with detergents, chlorinated hydro-carbons, ketones, esters or certain alcohols.
 - Do not use polycarbonate bowls or sight glasses in air systems where compressors are lubricated with fire resistant fluids such as phosphate ester and di-ester lubricants.

2.7. Chemical Compatibility: For more information on plastic component chemical compatibility see Pneumatic Division technical bulletins Tec-3, Tec-4, and Tec-5

- 2.8. Product Rupture:** Product rupture can cause death, serious personal injury, and property damage.
- Do not connect pressure regulators or other Pneumatic Division products to bottled gas cylinders.
 - Do not exceed the maximum primary pressure rating of any pressure regulator or any system component.
 - Consult product labeling or product literature for pressure rating limitations.

3. PRODUCT ASSEMBLY AND INSTALLATION INSTRUCTIONS

- 3.1. Component Inspection:** Prior to assembly or installation a careful examination of the valves, FRLs or vacuum products must be performed. All components must be checked for correct style, size, and catalog number. DO NOT use any component that displays any signs of nonconformance.
- 3.2. Installation Instructions:** Parker published Installation Instructions must be followed for installation of Parker valves, FRLs and vacuum components. These instructions are provided with every Parker valve or FRL sold, or by calling 1-800-CPARKER, or at www.parker.com.
- 3.3. Air Supply:** The air supply or control medium supplied to Valves, FRLs and Vacuum components must be moisture-free if ambient temperature can drop below freezing

4. VALVE AND FRL MAINTENANCE AND REPLACEMENT INSTRUCTIONS

- 4.1. Maintenance:** Even with proper selection and installation, valve, FRL and vacuum products service life may be significantly reduced without a continuing maintenance program. The severity of the application, risk potential from a component failure, and experience with any known failures in the application or in similar applications should determine the frequency of inspections and the servicing or replacement of Pneumatic Division products so that products are replaced before any failure occurs. A maintenance program must be established and followed by the user and, at minimum, must include instructions 4.2 through 4.10.
- 4.2. Installation and Service Instructions:** Before attempting to service or replace any worn or damaged parts consult the appropriate Service Bulletin for the valve or FRL in question for the appropriate practices to service the unit in question. These Service and Installation Instructions are provided with every Parker valve and FRL sold, or are available by calling 1-800-CPARKER, or by accessing the Parker web site at www.parker.com.
- 4.3. Lockout / Tagout Procedures:** Be sure to follow all required lockout and tagout procedures when servicing equipment. For more information see: OSHA Standard – 29 CFR, Part 1910.147, Appendix A, The Control of Hazardous Energy – (Lockout / Tagout)
- 4.4. Visual Inspection:** Any of the following conditions requires immediate system shut down and replacement of worn or damaged components:
- Air leakage: Look and listen to see if there are any signs of visual damage to any of the components in the system. Leakage is an indication of worn or damaged components.
 - Damaged or degraded components: Look to see if there are any visible signs of wear or component degradation.
 - Kinked, crushed, or damaged hoses. Kinked hoses can result in restricted air flow and lead to unpredictable system behavior.
 - Any observed improper system or component function: Immediately shut down the system and correct malfunction.
 - Excessive dirt build-up: Dirt and clutter can mask potentially hazardous situations.

Caution: Leak detection solutions should be rinsed off after use.

- 4.5. Routine Maintenance Issues:**
- Remove excessive dirt, grime and clutter from work areas.
 - Make sure all required guards and shields are in place.
- 4.6. Functional Test:** Before initiating automatic operation, operate the system manually to make sure all required functions operate properly and safely.
- 4.7. Service or Replacement Intervals:** It is the user's responsibility to establish appropriate service intervals. Valves, FRLs and vacuum products contain components that age, harden, wear, and otherwise deteriorate over time. Environmental conditions can significantly accelerate this process. Valves, FRLs and vacuum components need to be serviced or replaced on routine intervals. Service intervals need to be established based on:
- Previous performance experiences.
 - Government and / or industrial standards.
 - When failures could result in unacceptable down time, equipment damage or personal injury risk.
- 4.8. Servicing or Replacing of any Worn or Damaged Parts:** To avoid unpredictable system behavior that can cause death, personal injury and property damage:
- Follow all government, state and local safety and servicing practices prior to service including but not limited to all OSHA Lockout Tagout procedures (OSHA Standard – 29 CFR, Part 1910.147, Appendix A, The Control of Hazardous Energy – Lockout / Tagout).
 - Disconnect electrical supply (when necessary) before installation, servicing, or conversion.
 - Disconnect air supply and depressurize all air lines connected to system and Pneumatic Division products before installation, service, or conversion.
 - Installation, servicing, and / or conversion of these products must be performed by knowledgeable personnel who understand how pneumatic products are to be applied.
 - After installation, servicing, or conversions air and electrical supplies (when necessary) should be connected and the product tested for proper function and leakage. If audible leakage is present, or if the product does not operate properly, do not put product or system into use.
 - Warnings and specifications on the product should not be covered or painted over. If masking is not possible, contact your local representative for replacement labels.
- 4.9. Putting Serviced System Back into Operation:** Follow the guidelines above and all relevant Installation and Maintenance Instructions supplied with the valve FRL or vacuum component to insure proper function of the system.

Offer of Sale

The items described in this document and other documents or descriptions provided by Parker Hannifin Corporation, its subsidiaries and its authorized distributors, are hereby offered for sale at prices to be established by Parker Hannifin Corporation, its subsidiaries and its authorized distributors. This offer and its acceptance by any customer ("Buyer") shall be governed by all of the following Terms and Conditions. Buyer's order for any such item, when communicated to Parker Hannifin Corporation, its subsidiaries or an authorized distributor ("Seller") verbally or in writing, shall constitute acceptance of this offer.

1. Terms and Conditions of Sale: All descriptions, quotations, proposals, offers, acknowledgments, acceptances and sales of Seller's products are subject to and shall be governed exclusively by the terms and conditions stated herein. Buyer's acceptance of any offer to sell is limited to these terms and conditions. Any terms or conditions in addition to, or inconsistent with those stated herein, proposed by Buyer in any acceptance of an offer by Seller, are hereby objected to. No such additional, different or inconsistent terms and conditions shall become part of the contract between Buyer and Seller unless expressly accepted in writing by Seller. Seller's acceptance of any offer to purchase by Buyer is expressly conditional upon Buyer's assent to all the terms and conditions stated herein, including any terms in addition to, or inconsistent with those contained in Buyer's offer. Acceptance of Seller's products shall in all events constitute such assent.

2. Payment: Payment shall be made by Buyer net 30 days from the date of delivery of the items purchased hereunder. Amounts not timely paid shall bear interest at the maximum rate permitted by law for each month or portion thereof that the Buyer is late in making payment. Any claims by Buyer for omissions or shortages in a shipment shall be waived unless Seller receives notice thereof within 30 days after Buyer's receipt of the shipment.

3. Delivery: Unless otherwise provided on the face hereof, delivery shall be made F.O.B. Seller's plant. Regardless of the method of delivery, however, risk of loss shall pass to Buyer upon Seller's delivery to a carrier. Any delivery dates shown are approximate only and Seller shall have no liability for any delays in delivery.

4. Warranty: Seller warrants that the items sold hereunder shall be free from defects in material or workmanship for a period of 18 months from date of shipment from Parker Hannifin Corporation. THIS WARRANTY COMPRISES THE SOLE AND ENTIRE WARRANTY PERTAINING TO ITEMS PROVIDED HEREUNDER. SELLER MAKES NO OTHER WARRANTY, GUARANTEE, OR REPRESENTATION OF ANY KIND WHATSOEVER. ALL OTHER WARRANTIES, INCLUDING BUT NOT LIMITED TO, MERCHANTABILITY AND FITNESS FOR PURPOSE, WHETHER EXPRESS, IMPLIED, OR ARISING BY OPERATION OF LAW, TRADE USAGE, OR COURSE OF DEALING ARE HEREBY DISCLAIMED.

NOTWITHSTANDING THE FOREGOING, THERE ARE NOWARRANTIES WHATSOEVER ON ITEMS BUILT OR ACQUIRED WHOLLY OR PARTIALLY, TO BUYER'S DESIGN OR SPECIFICATIONS.

5. Limitation of Remedy: SELLER'S LIABILITY ARISING FROM OR IN ANY WAY CONNECTED WITH THE ITEMS SOLD OR THIS CONTRACT SHALL BE LIMITED EXCLUSIVELY TO REPAIR OR REPLACEMENT OF THE ITEMS SOLD OR REFUND OF THE PURCHASE PRICE PAID BY BUYER, AT SELLER'S SOLE OPTION. IN NO EVENT SHALL SELLER BE LIABLE FOR ANY INCIDENTAL, CONSEQUENTIAL OR SPECIAL DAMAGES OF ANY KIND OR NATURE WHATSOEVER, INCLUDING BUT NOT LIMITED TO LOST PROFITS ARISING FROM OR IN ANY WAY CONNECTED WITH THIS AGREEMENT OR ITEMS SOLD HEREUNDER, WHETHER ALLEGED TO ARISE FROM BREACH OF CONTRACT, EXPRESS OR IMPLIED WARRANTY, OR IN TORT, INCLUDING WITHOUT LIMITATION, NEGLIGENCE, FAILURE TO WARN OR STRICT LIABILITY.

6. Changes, Reschedules and Cancellations: Buyer may request to modify the designs or specifications for the items sold hereunder as well as the quantities and delivery dates thereof, or may request to cancel all or part of this order, however, no such requested modification or cancellation shall become part of the contract between Buyer and Seller unless accepted by Seller in a written amendment to this Agreement. Acceptance of any such requested modification or cancellation shall be at Seller's discretion, and shall be upon such terms and conditions as Seller may require.

7. Special Tooling: A tooling charge may be imposed for any special tooling, including without limitations, dies, fixtures, molds and patterns, acquired to manufacture items sold pursuant to this contract. Such special tooling shall be and remain Seller's property notwithstanding payment of any charges by Buyer. In no event will Buyer acquire any interest in apparatus belonging to Seller which is utilized in the manufacture of the items sold hereunder, even if such apparatus has been specially converted or adapted for such manufacture and notwithstanding any

charges paid by Buyer. Unless otherwise agreed, Seller shall have the right to alter, discard or otherwise dispose of any special tooling or other property in its sole discretion at any time.

8. Buyer's Property: Any designs, tools, patterns, materials, drawings, confidential information or equipment furnished by Buyer, or any other items which become Buyer's property, may be considered obsolete and may be destroyed by Seller after two (2) consecutive years have elapsed without Buyer placing an order for the items which are manufactured using such property. Seller shall not be responsible for any loss or damage to such property while it is in Seller's possession or control.

9. Taxes: Unless otherwise indicated on the face hereof, all prices and charges are exclusive of excise, sales, use, property, occupational or like taxes which may be imposed by any taxing authority upon the manufacture, sale or delivery of the items sold hereunder. If any such taxes must be paid by Seller or if Seller is liable for the collection of such tax, the amount thereof shall be in addition to the amounts for the items sold. Buyer agrees to pay all such taxes or to reimburse Seller therefore upon receipt of its invoice. If Buyer claims exemption from any sales, use or other tax imposed by any taxing authority, Buyer shall save Seller harmless from and against any such tax, together with any interest or penalties thereon which may be assessed if the items are held to be taxable.

10. Indemnity For Infringement of Intellectual Property Rights: Seller shall have no liability for infringement of any patents, trademarks, copyrights, trade dress, trade secrets or similar rights except as provided in this Part 10. Seller will defend and indemnify Buyer against allegations of infringement of U.S. patents, U.S. trademarks, copyrights, trade dress and trade secrets (hereinafter "Intellectual Property Rights"). Seller will defend at its expense and will pay the cost of any settlement or damages awarded in an action brought against Buyer based on an allegation that an item sold pursuant to this contract infringes the Intellectual Property Rights of a third party. Seller's obligation to defend and indemnify Buyer is contingent on Buyer notifying Seller within ten (10) days after Buyer becomes aware of such allegations of infringement, and Seller having sole control over the defense of any allegations or actions including all negotiations for settlement or compromise. If an item sold hereunder is subject to a claim that it infringes the Intellectual Property Rights of a third party, Seller may, at its sole expense and option, procure for Buyer the right to continue using said item, replace or modify said item so as to make it noninfringing, or offer to accept return of said item and return the purchase price less a reasonable allowance for depreciation. Notwithstanding the foregoing, Seller shall have no liability for claims of infringement based on information provided by Buyer, or directed to items delivered hereunder for which the designs are specified in whole or part by Buyer, or infringements resulting from the modification, combination or use in a system of any item sold hereunder. The foregoing provisions of this Part 10 shall constitute Seller's sole and exclusive liability and Buyer's sole and exclusive remedy for infringement of Intellectual Property Rights.

If a claim is based on information provided by Buyer or if the design for an item delivered hereunder is specified in whole or in part by Buyer, Buyer shall defend and indemnify Seller for all costs, expenses or judgements resulting from any claim that such item infringes any patent, trademark, copyright, trade dress, trade secret or any similar right.

11. Force Majeure: Seller does not assume the risk of and shall not be liable for delay or failure to perform any of Seller's obligations by reason of circumstances beyond the reasonable control of Seller (hereinafter "Events of Force Majeure"). Events of Force Majeure shall include without limitation, accidents, acts of God, strikes or labor disputes, acts, laws, rules or regulations of any government or government agency, fires, floods, delays or failures in delivery of carriers or suppliers, shortages of materials and any other cause beyond Seller's control.

12. Entire Agreement/Governing Law: The terms and conditions set forth herein, together with any amendments, modifications and any different terms or conditions expressly accepted by Seller in writing, shall constitute the entire Agreement concerning the items sold, and there are no oral or other representations or agreements which pertain thereto. This Agreement shall be governed in all respects by the law of the State of Ohio. No actions arising out of sale of the items sold hereunder or this Agreement may be brought by either party more than two (2) years after the cause of action accrues.